

# FEEDER STORAGE, SETUP & STAGING

REDUCE DOWNTIME ON SMT LINES

*SMART HANDLING SOLUTIONS*

A.



C.



B.

# FEEDER STORAGE, SETUP & STAGING

INCREASES THROUGHPUT AND CAPACITY OF YOUR LINE

## FEATURES

- Reduces downtime during changeover and reloads. Increases throughput
- Supports all major feeder brands
- Protects expensive feeders from damage
- Minimizes handling
- Enclosable configurations available
- Fully adjustable
- Shock absorbing casters prevent damage to delicate feeders
- Built in ESD protection

Custom sizes and features available

See all the options and accessories online

[www.blissindustries.com](http://www.blissindustries.com)

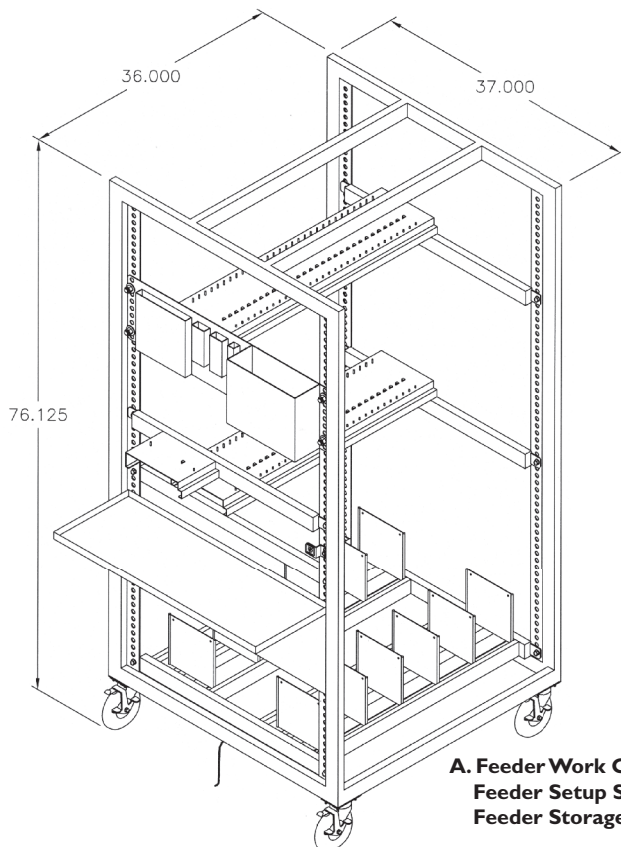

**A. Feeder Work Center with Feeder Setup Station, Feeder Storage & Reel Storage**

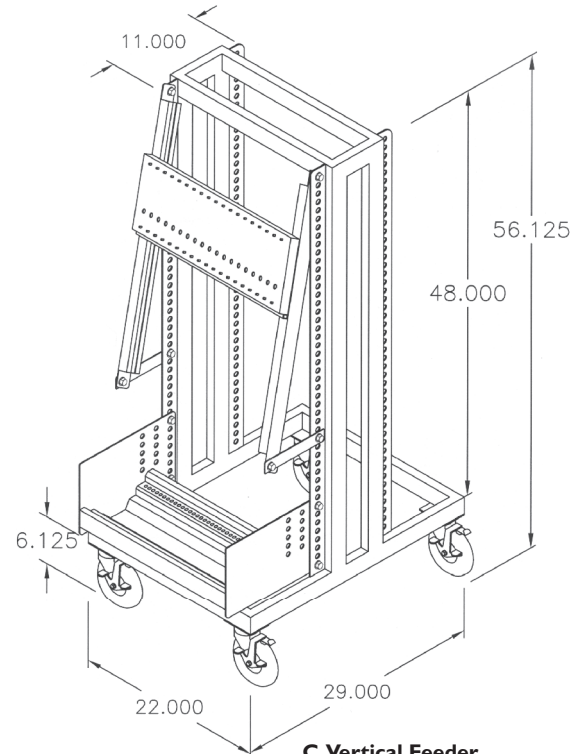

**C. Vertical Feeder Storage Cart**

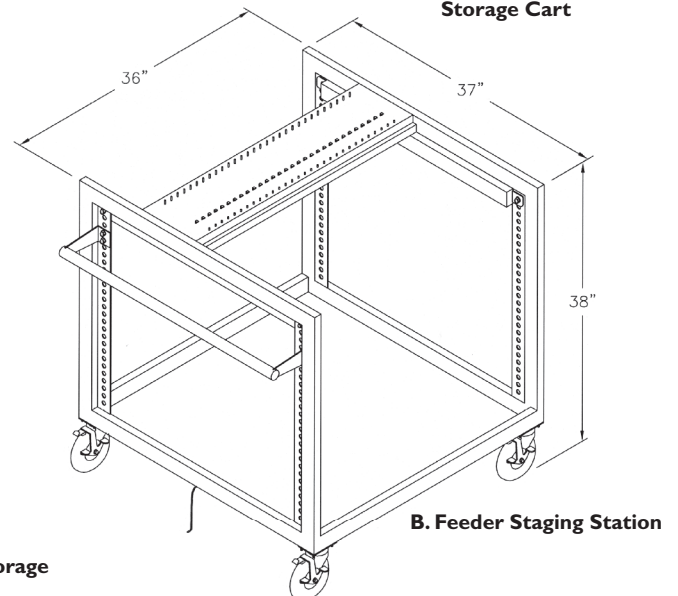

**B. Feeder Staging Station**

**Bliss Feeder Carts** are designed to safely store component feeders and reels. By adding an adjustable shelf, tool panel, feeder setup rack, and a wrist strap ground plug, the carts can be used as a modular feeder work center. Feeder staging carts are used at the pick & place machine or as a job cart to transport the feeders and reels from a staging area. Feeders are securely held in place. Completely surrounded by the cart frame, all feeders are protected from accidental damage. **Bliss Industries has feeder racks for every feeder manufacturer.**

**Bliss Feeder Staging Stations** are designed to permit rapid changeover of feeders on pick & place machines. Exchanging feeders position-for-position, the machine can be up and running in less than 10 minutes. Previous setups can be taken down off-line after new jobs are running. Reduces down-time during changeover by as much as 1 hour.

**Bliss Vertical Feeder Handling Carts** are designed to store and stage component feeders with a latching mechanism and component reel in a vertical position. Feeders are securely held in place. All major feeder types with a latching mechanism are supported. This style cart is ideal when production lines are separated by narrow aisles.

**A Step Towards Lean Manufacturing**  
Complete details and catalog online



**BLISS**  
INDUSTRIES, INC.

386 Railroad Ct.  
Milpitas, CA 95035

Phone: 408-945-8401 • Fax: 408-945-1914

[sales@blissindustries.com](mailto:sales@blissindustries.com) • [www.blissindustries.com](http://www.blissindustries.com)